

MODEL

1000

*Builder Series
Non-Programmable
Single Stage Heat/Cool
Thermostat*

USER MANUAL

Compatible with low voltage single stage gas, oil or electric heating or cooling systems, including single stage heat pumps. This thermostat can also be used on 250mv to 750mv millivolt heating only systems. Do not use this thermostat on applications with voltages above 30 Volts AC.

READ ALL INSTRUCTIONS BEFORE PROCEEDING

CONTENTS

- 1 SPECIFICATIONS
- 2 INSTALLATION
- 3 TESTING YOUR NEW THERMOSTAT
- 4 PROGRAMMING USER SETTINGS
- 5 ADDITIONAL OPERATION FEATURES
- 6 TROUBLESHOOTING
- 7 WIRING DIAGRAMS

- Always turn off power to the air conditioning or heating system prior to installing, removing, cleaning or servicing thermostat.
- Read this manual thoroughly prior to installing, programming or operating this thermostat.
- This thermostat is designed for use with a 24 Volt-AC low voltage single stage gas, oil or electric heating or cooling systems, including single stage heat pumps. This thermostat can also be used on 250mv to 750mv millivolt heating only systems.
- Do not use this thermostat on applications with voltages above 30 Volts AC.
- This thermostat requires two (2) properly installed "AA" alkaline batteries to provide power for the thermostat to properly control the system operation.
- The system must have 24 Volt AC power present for proper system operation and control.
- Wiring must conform to all building codes and ordinances as required by local and national code authorities having jurisdiction.
- Do not short (or jumper) across terminals on the gas valve or at the heating or cooling system control board to test the thermostat installation. This could damage the thermostat and void the warranty.
- Do not select COOL mode of operation if the outside temperature is below 50° F (10° C). This could possibly damage the controlled cooling system and may cause personal injury.
- This thermostat should only be used as described in this manual. Any other use is not recommended and will void the warranty.

1 SPECIFICATIONS

- Electrical Rating: 24 Volt AC (18-30 Volt AC)
 - 1 amp maximum load per terminal
 - 2 amp total maximum load (all terminals)
- Control Range: 45° - 90° F (7° - 32° C)
- Accuracy: +/- 1° F (+/- .5° C)
- DC Power: 3.0 Volt DC (2 AA Alkaline batteries included)
- Compatibility with low voltage single stage gas, oil or electric heating or cooling systems, including single stage heat pumps. This thermostat can also be used on 250mv to 750mv millivolt heating only systems.
- Terminations: Rc, Rh, G, W, Y, B, O

2 INSTALLATION

2.1 Replacing Existing Thermostat

1. Always turn off power to the air conditioning or heating system prior to removing existing thermostat.
2. Remove the cover of your old thermostat and locate the wire terminals. Do not remove wires from terminals yet.
3. Using small pieces of masking tape label wires prior to removal from terminals. Use the chart below to determine the new terminal designations for your new thermostat.

Old Terminal from Existing Thermostat	New Terminal for New Thermostat	Terminal Description
V or Rc	Rc	Cooling Transformer
M, 4, Rh, or R	Rh	Heating Transformer
B	B	Reversing Valve (Heating)
O	O	Reversing Valve (Cooling)
Y	Y	Cooling or Compressor for HP system
H,W, or 4	W	Heating
G or F	G	Fan Control

4. After labeling and removing all wires from terminals, unscrew the existing thermostat sub-base from wall. Make sure to secure wires to prevent them from slipping back into the hole in the wall.

NOTE: This thermostat is designed for use with a 24 Volt-AC low voltage single-stage gas, oil or electric heating or cooling systems, including single stage heat pumps. This thermostat can also be used on 250mv to 750mv millivolt heating only systems. Do not use this thermostat on applications with voltages above 30 Volts AC.

2.2 Installing Your New Thermostat

NOTE: If you are installing this thermostat in a new installation be sure to locate the thermostat 4 to 5 feet above the floor in accordance with applicable building codes. Make sure to install the thermostat in a location that provides good airflow characteristics and avoid areas behind doors, near corners, air vents, direct sunlight or near any heat generating device. Installation in any of these areas could impact thermostat performance.

1. Always turn off power to the air conditioning or heating system prior to installing your new thermostat.
2. Place system switch on front of thermostat to **OFF** position.
3. Place fan control switch on front of thermostat to **AUTO** position.
4. Remove front of thermostat body from sub-base by pressing release latch on bottom of front body.
5. Place the thermostat sub-base against wall in the desired thermostat location.
6. Guide thermostat wires through center hole in sub-base. Continue to hold sub-base against wall.
7. Mark placement of mounting holes as appropriate and drill using a 3/16" drill bit.
8. Gently tap supplied plastic anchors into the holes in the wall.
9. Place the thermostat sub-base against the wall in the desired location, making sure the mounting holes are aligned as appropriate and the thermostat wires are properly inserting through opening in middle of sub-base.

2 INSTALLATION *cont.*

2.2 Installing Your New Thermostat *cont.*

10. Fasten the sub-base to wall using supplied screws.
11. Connect wires to quick wiring terminal block as appropriate using the new terminal designations. Refer to *Wiring Diagram* section of this manual if required for assistance.
12. Make sure all of the wire connections are secure and are not touching any other terminal to prevent electrical shorts and potential damage to the thermostat.
13. Turn the front thermostat body over exposing the rear view of the circuit board
14. Locate the internal °F / °C switch on the circuit board.
15. Using your fingers, gently flip the switch toward the preferred temperature °F / °C scale.
16. Locate the internal fan option switch, **HG** (Gas) / **HE** (Elec) on the circuit board. This switch controls the heating system fan delay. Select gas for gas or oil fired systems. This will allow the furnace to run for a few seconds before initiating the fan. Select electric for systems with electric furnace elements that require the fan to come on immediately.
17. Using your fingers, gently flip the switch towards the **HG** (Gas) or **HE** (Elec) selection that indicates the low voltage heating system the thermostat will control.
18. Locate the internal **NORM NON-HP** / **HP** switch on the circuit board. This switch configures the thermostat for normal (NORM NON-HP) heating and cooling systems or heat pump (HP) systems.
19. Using your fingers, gently flip the switch towards the **NORM NON-HP** or **HP** selection that indicates the low voltage heating system the thermostat will control.
20. Attach front body of thermostat to sub-base of thermostat, being careful to align the terminal pins on the front body with the terminal block on the sub-base.
21. Open front thermostat door and open battery compartment door.
22. Install two new "AA" alkaline batteries into battery compartment. Make sure to locate the positive (+) ends of the batteries and match them with the positive (+) terminals located in the battery compartment.
23. Close battery compartment.
24. Restore system power so you can test installation.

NOTE: If you installed the batteries prior to accomplishing steps 14 through 19, then you will need to reset the thermostat to register your thermostat switch configurations prior to programming any user settings. Gently press the **RESET** button on the front of the thermostat using a paperclip or a small pencil tip.

3 TESTING YOUR NEW THERMOSTAT

WARNING! Read *BEFORE* Testing

- Do not short (or jumper) across terminals on the gas valve or at the heating or cooling system control board to test the thermostat installation. This could damage the thermostat and void the warranty.
- Do not select COOL mode of operation if the outside temperature is below 50° F (10° C). This could possibly damage the controlled cooling system and may cause personal injury.
- This thermostat includes an automatic compressor protection feature to avoid potential damage to the cooling system from short cycling. This thermostat automatically provides a 5-minute delay after turning off the cooling system output to protect the compressor. This protection is also present in the heat mode of operation on single stage heat pump systems to protect the compressor.

NOTE: Test your thermostat prior to programming any user settings. Pressing the **RESET** button will erase any user entries previously programmed. This will erase all user settings and return them to their default values.

3 TESTING YOUR NEW THERMOSTAT *cont.*

1. Place the system switch in the **HEAT** position.
2. Press the \wedge button on the keypad until the setpoint temperature setting is a minimum of 3 degrees higher than the current room temperature. The heating system should start within several seconds. The fan may not turn on immediately due to the heating system built-in fan delay.
3. Place the system switch in the **OFF** position. The heating system should stop within several seconds on normal single stage heating or cooling systems. On single stage heat pump systems you must wait 5 minutes for the automatic compressor short cycle protection period to expire, or press the **RESET** button to bypass this feature for initial testing purposes. Pressing the **RESET** button will erase any user program settings.
4. Place the system switch in the **COOL** position.
5. Press the \vee button on the keypad until the setpoint temperature is a minimum of 3 degrees lower than the current room temperature.
6. The cooling system should start within several seconds. Place the system switch in the **OFF** position. The cooling system should stop within a few seconds.
7. Place the fan switch in the **ON** position. The system blower should start.
8. Place the fan switch in the **AUTO** position. The system blower should stop.

4 PROGRAMMING USER SETTINGS

4.1 Default Thermostat Settings

Function	Status After Reset
Operation Mode	Normal Operating Mode
Room Temperature	70° F (21.0° C), to be renewed within 5 seconds
Setpoint Temperature	According to system switch: 62° F (17.0° C) for Heat or Off 85° F (29.0° C) for Cool
Temperature Scale	F or °C dependent on switch setting
Low Battery Warning	Off, to be renewed within 5 seconds
Temperature Differential	0.5° F (0.25° C)
Short Cycle Protection Timer	Reset
Output Relays	Off

4.2 Setting Temperature Differential

The default settings for the temperature differential is compatible with most systems and applications. The temperature differential is normally set at time of installation and usually does not require any modification under normal operating conditions. If you feel that your system is turning on too often, simply follow the instructions below.

NOTE: *The temperature differential settings are the same for both the heating and cooling systems.*

The default setting is 0.5° F (0.25° C). The room temperature must change .5° F (0.25° C) from the setpoint temperature before the thermostat will initiate the system in heating or cooling.

1. In normal operating mode, press and hold both the \wedge and \vee buttons at the same time for 4 seconds. LCD display will show "SET D1 x", where "x" equals the F / °C differential setting. This is the current temperature differential setting.



2. Press the \wedge or \vee buttons to set the temperature differential to your desired setting of .5°, 1°, or 2° F (.25—displayed as .2°, .5° or 1° C).

4 PROGRAMMING USER SETTINGS *cont.*

4.2 Setting Temperature Differential *cont.*

NOTE: *Once you have finished setting the temperature differential you can wait 5 seconds and the thermostat will automatically return to the normal operating mode. Otherwise, you can press both the \wedge and \vee buttons at the same time again to return you to normal operating mode.*

NOTE: *To erase all user program settings, gently press **RESET** button using a paperclip or a small pencil tip. This will return all thermostat settings to their default values.*

5 ADDITIONAL OPERATION FEATURES

5.1 Review Set Temperature

1. Press and hold \wedge or \vee button. The current setpoint temperature will be displayed in the place of the current room temperature, and the indicator **SET** will be displayed.
2. The display will return to normal operating mode when the \wedge or \vee buttons are released. The **SET** indicator will turn off indicating that the current temperature shown in the display is the room temperature. Continuing to hold the \wedge or \vee button for 3 seconds or longer will allow the user to change the current setpoint temperature (See *Changing Set Temperature*).



5.2 Changing Set Temperature

1. Press and hold \wedge or \vee button for 3 seconds. The entire display will flash once and the **SET** indicator will be flashing. Release the \wedge or \vee button and press the \wedge or \vee button again as desired to adjust the set temperature.
2. The display will return to normal operating mode after 5 seconds, or you can press both the \wedge and \vee buttons at the same time to return to normal operating mode.
3. The **SET** indicator will turn off in the display, indicating that the current temperature shown in the display is the room temperature.



5 ADDITIONAL OPERATION FEATURES *cont.*

5.3 Low Temperature "Freeze" Protection

While the thermostat is in the **HEAT** mode of operation on standard heating (non-heat pump) applications, the thermostat will mechanically initiate a call for heat if the room temperature drops to less than 41°F (5°C). The system selector switch must be in the **HEAT** position for this feature to be active. This feature will allow the thermostat to initiate a call for heat on standard heating (non-heat pump) applications, to provide a minimum amount of heat, even if the batteries are dead or missing. Call a Professional service technician immediately to verify proper system operation. This feature is only active on standard heating (non-heat pump) applications and is not available on single stage heat pump applications.

5.4 Compressor Protection Feature

This thermostat includes an automatic compressor protection feature to avoid potential damage to the cooling system from short cycling. This thermostat automatically provides a 5-minute delay after turning off the cooling system output to protect the compressor. This protection is also present in the heat mode of operation on single stage heat pump systems to protect the compressor.

NOTE: *The installer can reset the thermostat and bypass the compressor protection feature by pressing the **RESET** button. This will erase all user program settings and should only be used during installation for testing purposes or to reset a thermostat to regain normal operation. This will return all Thermostat settings to their default values.*

5.5 Low Battery Detection and Replacement

This thermostat requires two (2) properly installed "AA" alkaline batteries to provide power for the thermostat to properly control the system operation. The system must have 24 Volt AC power present for proper system operation and control.

This thermostat is equipped with a low battery detection feature that constantly monitors the batteries during normal operating mode to determine whether they have sufficient power to provide proper operation.

When this feature determines that the battery status is low, a low battery indicator will appear in the display. It is recommended that the batteries be replaced immediately to maintain system operation and program settings.



5.5.1 Replacing the Batteries

1. Open front thermostat door and locate the battery compartment door.
2. Gently remove the two "AA" alkaline batteries located in the battery compartment.
3. Install two new "AA" alkaline batteries into battery compartment. Make sure to match the positive (+) ends of the batteries with the positive (+) terminals located in the battery compartment.
4. Close battery compartment and verify that the low battery indicator does not appear in the display.

5 ADDITIONAL OPERATION FEATURES *cont.*



5.6 Resetting The Thermostat

The Reset feature allows the user to completely reset the thermostat to register new manual switch settings and return to factory set software settings.

1. To erase all entered settings, gently press **RESET** button using a paper clip or a small pencil tip.
2. This will return all thermostat settings to their default values and register all new manual switch settings for proper operation.

6 TROUBLESHOOTING

SYMPTOM	POTENTIAL SOLUTION
Thermostat does not turn on heating or cooling system.	<p>Check to see if OFF is shown in display. This indicates that the system is turned off at the thermostat. Move the system selector switch to the HEAT or COOL position. After the compressor short cycle protection 5-minute period expires the system should start within a minutes time.</p> <p>Compressor protection features may be in effect due to compressor short cycle conditions. See <i>Compressor Protection Feature</i> section for full explanation of this feature.</p> <p>Heating or cooling system may be malfunctioning. Call a professional service technician immediately to verify system operation.</p>
Thermostat turns on heating instead of cooling, or cooling instead of heating.	Check thermostat wiring to make sure that the heating and cooling stages are connected to the correct terminals on the wiring terminal block. See <i>Installation and Wiring Diagrams</i> sections of this manual.
Thermostat turns heating or cooling system on too often or not often enough.	Increase or decrease temperature differential setting as appropriate to provide the desired performance level. See <i>Setting Temperature Differential</i> section of this manual.
Low battery indicator is shown in thermostat display.	Replace batteries immediately to maintain proper system operation. See <i>Low Battery Detection and Replacement</i> section of this manual.
OFF is shown in thermostat display and heating or cooling system will not start.	<p>This indicates that the system is turned off at the thermostat. The thermostat must be in HEAT or COOL modes of operation to control the heating or cooling system. Move the system selector switch to the HEAT or COOL position.</p> 

SYMPTOM	POTENTIAL SOLUTION
Thermostat display is blank.	It is possible that the batteries are drained and not providing power for the thermostat to control the system. Replace batteries immediately to maintain proper system operation. See <i>Low Battery Detection and Replacement</i> section of this manual. If you replace the batteries and the display does not appear, call a professional service technician to verify thermostat and system performance.
<p>HI is shown in the thermostat display where the room temperature is normally displayed.</p> 	<p>The temperature sensed by the thermostat is higher than the 90° F (32° C) upper limit of the thermostats display range. The display will return to normal after the sensed temperature lowers within the 45° to 90° F (7° to 32° C) display range. Turn on the cooling system or use other methods to lower the temperature accordingly.</p> <p>This condition could occur from the system being turned off during an exceptionally warm period or upon installation when the thermostat has been stored for a long period of time in a warm vehicle or location prior to being installed. The thermostat is equipped with a mechanical high temperature safety switch that will turn off the thermostat should the temperature exceed 99° F (37° C) in the heat mode.</p>
<p>LO is shown in the thermostat display where the room temperature is normally displayed.</p> 	<p>The temperature sensed by the thermostat is lower than the 45° F (7° C) lower limit of the thermostats display range. The display will return to normal after the sensed temperature rises within the 45° to 90° F (7° to 32° C) display range. If the temperature in the controlled space seems to be normal, wait for the thermostat to acclimate to the correct room temperature. If the room seems to be colder than usual, turn on the heating system to raise the temperature as needed for comfort within the room.</p> <p>This condition could occur from the system being turned off during a cold weather period or upon installation when the thermostat has been stored for a long period of time in a cold vehicle or location prior to being installed. The thermostat should be allowed to warm up prior to installation to allow proper heating control once installed.</p>
Thermostat will not allow me to program a setpoint temperature higher than 90° F (32° C).	This is above the normal thermostat temperature setting range of 45° to 90° F (7° to 32° C).

SYMPTOM	POTENTIAL SOLUTION
Thermostat will not allow me to program a setpoint temperature lower than 45° F (7° C).	This is below the normal thermostat temperature setting range of 45° to 90° F (7° to 32° C).
Fan continues to run all the time whether the system is on or off.	<p>Check that the fan control switch is in the AUTO position. This will allow the fan to run only when the heating or cooling system is turned on and running.</p> <p>Check thermostat wiring to make sure that the fan control wiring is connected to the correct terminals on the wiring terminal block. See <i>Installation and Wiring Diagrams</i> sections of this manual.</p>
The room is too warm or too cold.	See <i>Review Set Temperature</i> section of this manual to verify the current setpoint and make any modifications that are necessary.

7 WIRING DIAGRAMS

Typical 2-Wire 24 Volt AC or 250mV - 750mV Millivolt Heating Systems

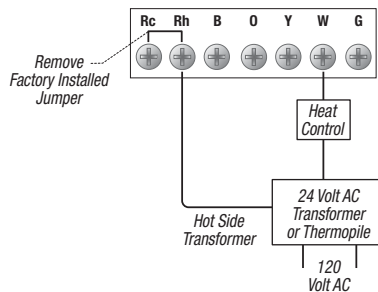

Typical 4-Wire Single Transformer Heating and Cooling System

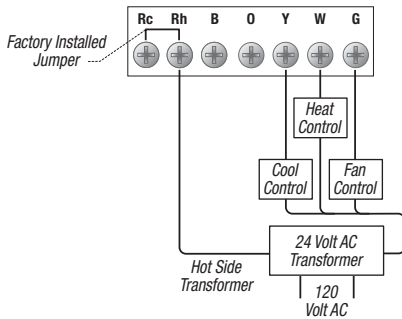

NOTE: For heating or cooling only system ignore opposite connection.

Typical 5-Wire Two Transformer Heating and Cooling System

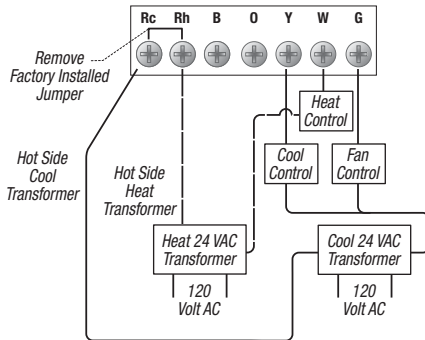

Typical Single Stage Heat Pump System

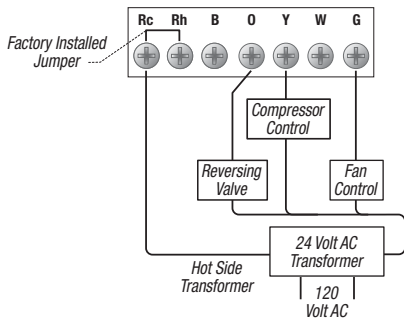

NOTE: For reversing valve active in heating use B terminal instead of O terminal.

5 YEAR
LIMITED
WARRANTY

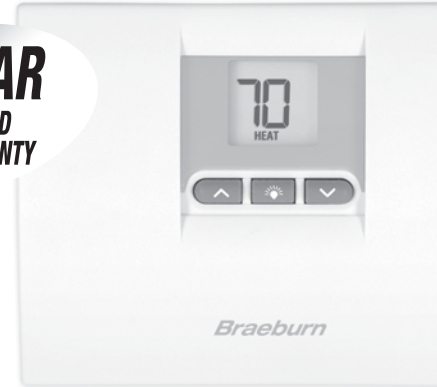

Store this
booklet for
future reference

Braeburn Systems LLC warrants each new Braeburn thermostat against any defects that are due to faulty material or workmanship for a period of five years after the original date of purchase by a professional service technician. This warranty and our liability does not apply to batteries, nor does it include damage to merchandise or the thermostat resulting from accident, alteration, neglect, misuse, improper installation or any other failure to follow Braeburn installation and operating instructions.

Braeburn Systems LLC agrees to repair or replace at its option any Braeburn thermostat under warranty provided it is returned postage prepaid to our warranty facility in a padded carton within the warranty period, with proof of the original date of purchase and a brief description of the malfunction. This limited warranty does not include the cost of removal or re-installation.

This warranty gives you specific legal rights and you may also have other rights that vary from state to state or province to province. Answers to any questions regarding our limited warranty may be obtained by writing our corporate offices.

WARRANTY FACILITY: Braeburn Systems LLC
Attn: Warranty Department
2215 Cornell Avenue
Montgomery, IL 60538

Braeburn®

Braeburn Systems LLC
2215 Cornell Avenue • Montgomery, IL 60538
Technical Assistance: www.braeburnonline.com
Call us toll-free: 866-268-5599 (U.S. Only)
630-844-1968 (Outside the U.S.)